

Installation, Operation and Maintenance Manual

Please read and save these instructions for future reference. Read carefully before attempting to assemble, install, operate or maintain the product described. Protect yourself and others by observing all safety information. Failure to comply with these instructions will result in voiding of the product warranty and may result in personal injury and/or property damage.

Maximum Wind-load: +/-150 PSF

Channel Installation

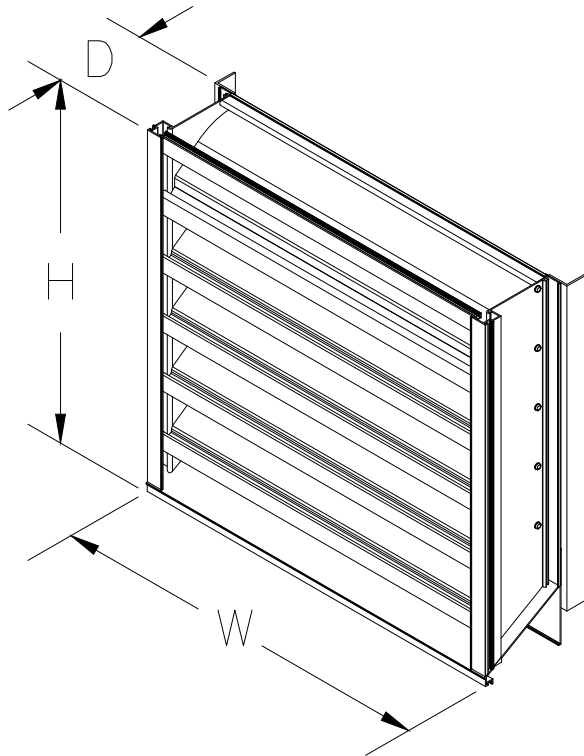

Flange/Sleeve Installation

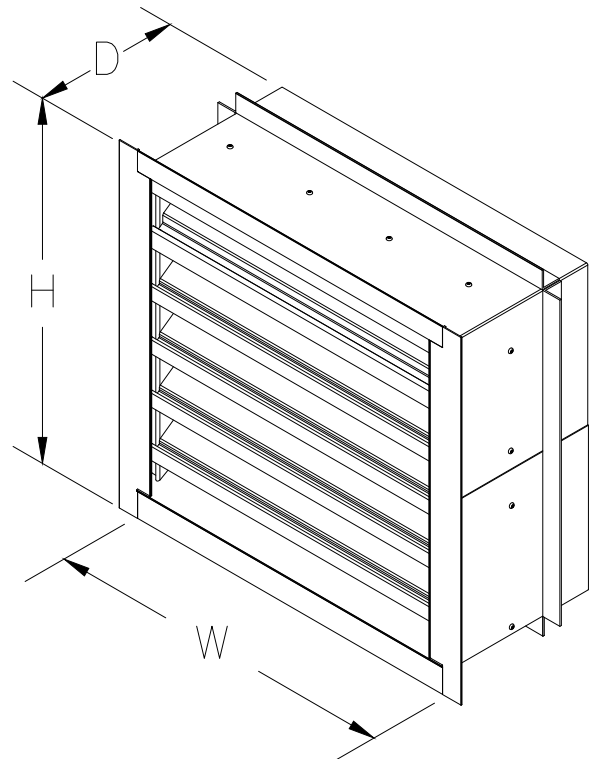

Channel Installation

Maximum Size and Installation Information

Model K6746MDE is a Miami-Dade Approved and Florida Product Approved louver and must be installed in accordance with the installation instructions shown herein. Model K6746MDE is qualified for installation within concrete/masonry, steel stud, structural steel or wood framed building conditions. Model K6746MDE is structurally calculated to withstand positive and negative wind-loads up to +/-150 PSF. The maximum typical rough opening height is limited to 48.50 in. and the typical rough opening width is limited to 48.75 in.

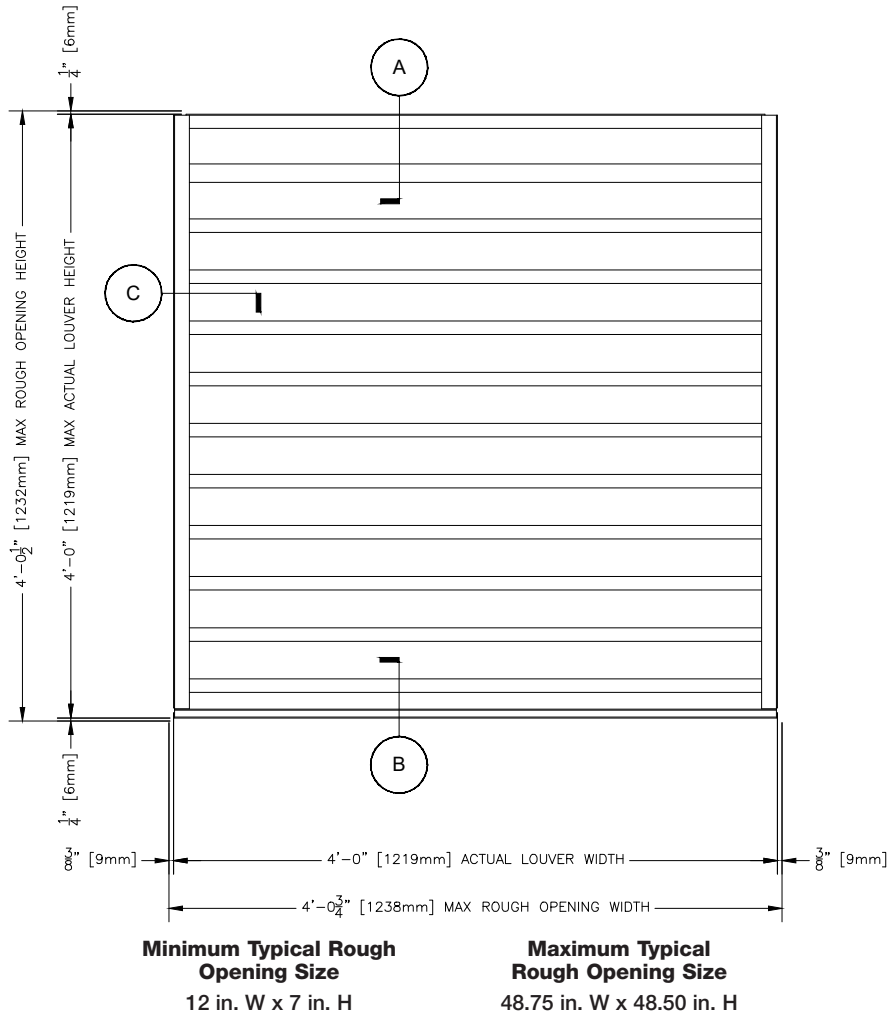

Building Condition/Substrate Limitations

Channel Installation

- All steel substrate should be min. 16 Ga. FY= 33 KSI
- All concrete substrate shall be min. 2000 PSI
- All concrete masonry shall be ASTM C90, Type II, grout-filled
- All wood substrate shall be G= 0.42 density or better
- All aluminum substrate shall be min 0.125 in. thick FY=16 KSI

Channel Installation

A HEAD DETAIL

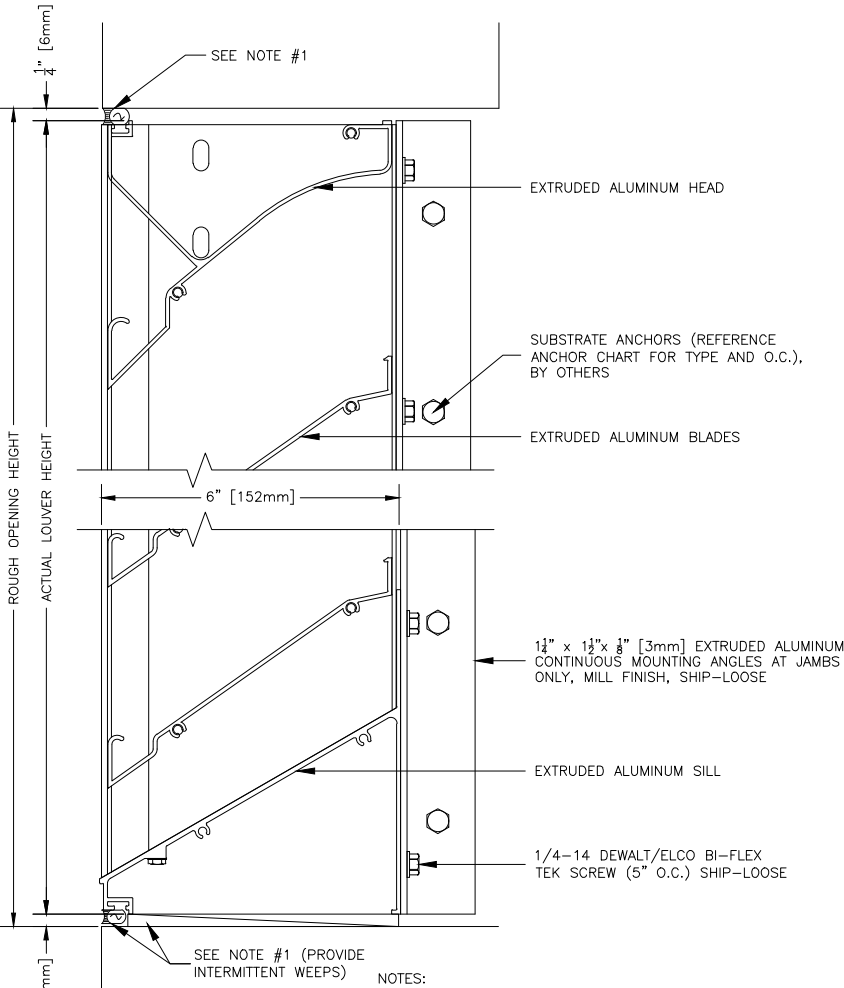

B SILL DETAIL

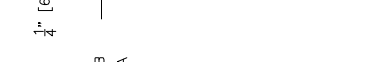

NOTES:
 1: ALL SEALANT, BACKER ROD, NON-COMPRESSIBLE DEAD-LOAD SHIMS AND SUBSTRATES ARE NOT BY AIROLITE (TYPICAL ALL DETAILS).
 2A: EDGE DISTANCE REQUIREMENTS IN ANCHOR CHART (VARIES BY SUBSTRATE).
 2B: IF EDGE DISTANCE REQUIREMENTS CANNOT BE MET W/ANGLE IN ORIGINAL ORIENTATION, CONTINUOUS MOUNTING ANGLES MAY BE USED IN ALT. ORIENTATION.
 3: SEPARATION OF DIS-SIMILAR MATERIALS RECOMMENDED (NOT BY AIROLITE).

C JAMB DETAIL

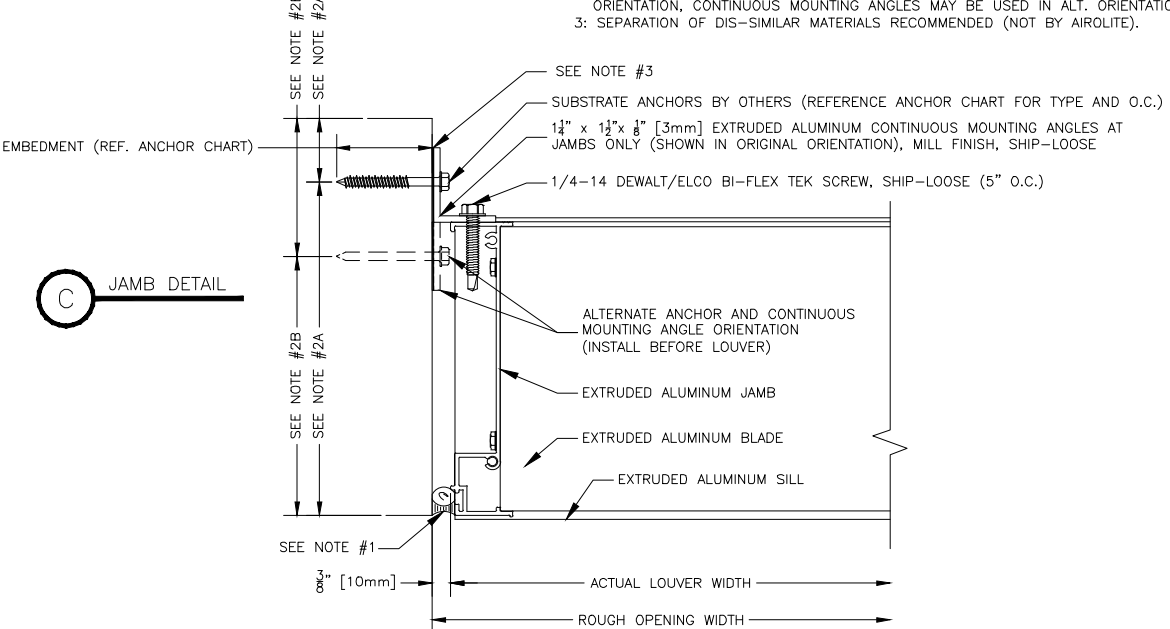

Channel Installation

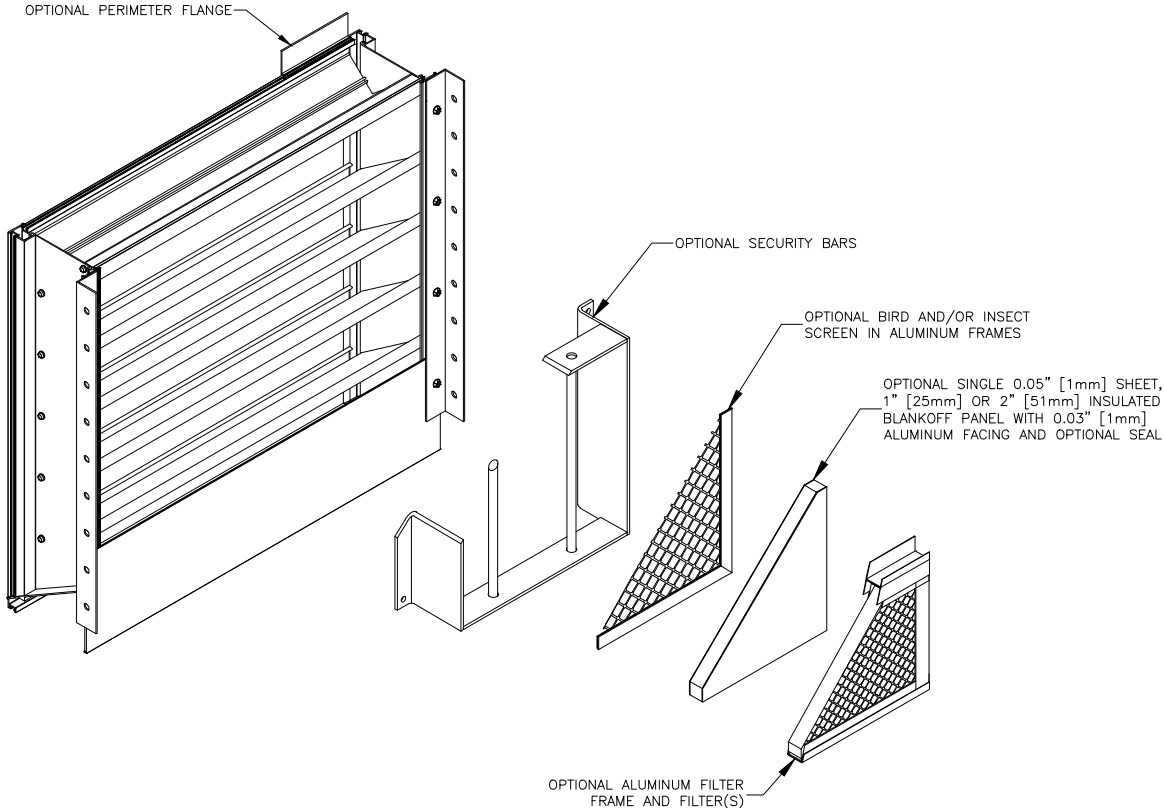

Channel Installation

SUBSTRATE AND SUBSTRATE FASTENER TABLE																
SUBSTRATE			SUBSTRATE FASTENER													
TYPE	THICKNESS MIN	MATERIAL MIN	TYPE (ALL FASTENERS ARE HEX HEAD STYLE)	MAT'L	DIA.	EDGE MIN	EMBED MIN	SPACING MAX *	SPACING MIN *	HEAD DIA. MIN	ANGLE HOLE ITEM 5, MAX	SUBSTRATE HOLE, MAX				
WOOD	3	G DF 0.42	LAG SCREW, 3 INCH MIN LENGTH	300 SS	1/4	1 1/2	23/32	5 3/4	3	1/2	5/16	SEE FASTENER MANUFACTURER INSTRUCTIONS				
					3/8	1 1/2	23/32	6 1/4		5/8						
STEEL	16 GA (0.056)	Fy 33 KSI Fu 45 KSI	1/4-20 BOLT W/ NUT	300 SS	1/4	5/8	0.056	8	1	1/2 HEAD 9/16 NUT	5/16	5/16				
	14 GA (0.070)		1/4-14 DEWALT/ELCO BI-FLEX SCREW, 300 SS HEAD & SHANK W/ COATED STEEL TIP	MULTI				5 5/8		1/2			SEE FASTENER MANUFACTURER INSTRUCTIONS			
	12 GA (0.099)							0.070						6 3/4	0.099	8
ALUMINUM	1/8	6063-T5	1/4-20 BOLT W/ NUT	300 SS	1/4	1/2	1/8	8	1	1/2 HEAD 9/16 NUT	5/16	1/4				
			1/4-14 DEWALT/ELCO BI-FLEX SCREW, 300 SS HEAD & SHANK W/ COATED STEEL TIP	MULTI				7		1/2		SEE FASTENER MANUFACTURER INSTRUCTIONS				
CONCRETE	VARIES WITH SIZE OF FASTENER USED, SEE FASTENER MANUFACTURER INSTRUCTIONS	2 KSI	BUILDEX TAPCON, STAINLESS	410 SS	1/4	1 1/2	1 1/2	4	2	AS MANUFACTURED	1/4	SEE FASTENER MANUFACTURER INSTRUCTIONS				
						2 1/8		6								
		3 KSI	DEWALT/ELCO AGGRE-GATOR	300 SS	1/4	1 1/2	1 3/8	6	3		6		3	1/4		
														1	4	
		2.9 KSI	DEWALT/ELCO ULTRACON SS4	410 SS	1/4	2 1/2	1 3/4	8	6		6		6	1/4		
														3	6	
		3.4 KSI	DEWALT/ELCO CRETE-FLEX SS4, SMALL HEAD	410 SS	1/4	1	1 3/4	8	8		8		1	1/4		
														DEWALT/ELCO CRETE-FLEX SS4, FLANGED HEAD	6	
		2.5 KSI	DEWALT/POWERS 316 STAINLESS STEEL WEDGE-BOLT	316 SS	1/4	3/8	2 3/8	4	2 3/8		4		1	5/16		
								2			6					
1 1/8	4															
1 5/8	6															
GROUT FILLED CMU	NOTE 1	DEWALT/ELCO AGGRE-GATOR	300 SS	1/4	2	2	8	3	AS MANUFACTURED	1/4						
										NOTE 2	DEWALT/ELCO ULTRACON SS4	410 SS	1/4	1	2	1 1/2
														25	6	3
NOTE 3	DEWALT/ELCO CRETE-FLEX SS4, FLANGED HEAD	410 SS	1/4	1 3/4	1 1/4	6	6	6	1/4							

NOTE *: MANUFACTURER MAY PROVIDE PILOT HOLES IN MOUNTING ANGLE AT 2" O.C. FOR SUBSTRATE ANCHOR. INSTALLER SHALL USE HOLES WHICH DO NOT VIOLATE SHOWN MIN & MAX SPACING.
 NOTE 1: CONCRETE MASONRY (CMU) SHALL BE > THE FOLLOWING: 6" WIDE, CMU CONFORMING TO ASTM C-90 FILLED WITH 4,747 PSI GROUT.
 NOTE 2: CONCRETE MASONRY (CMU) SHALL BE > THE FOLLOWING: 6" WIDE, 2 KSI CMU CONFORMING TO ASTM C-90 FILLED WITH 1624 PSI GROUT.
 NOTE 3: CONCRETE MASONRY (CMU) SHALL BE > THE FOLLOWING: 6" WIDE, CONFORMING TO ASTM C-90 FILLED WITH 3,350 PSI GROUT.

Flange/Sleeve Installation

Maximum Size and Installation Information

Model K6746MDE is a Miami-Dade Approved and Florida Product Approved louver and must be installed in accordance with the installation instructions shown herein. Model K6746MDE with Flange/Sleeve is qualified for installation into any substrate that can withstand the loads transferred by the louver, including but not limited to concrete/masonry, aluminum, steel stud, structural steel or wood framed building conditions. Model K6746MDE is structurally calculated to withstand positive and negative wind-loads up to +/-150 PSF. The maximum typical rough opening height is limited to 48.50 in. and the typical rough opening width is limited to 48.5 in.

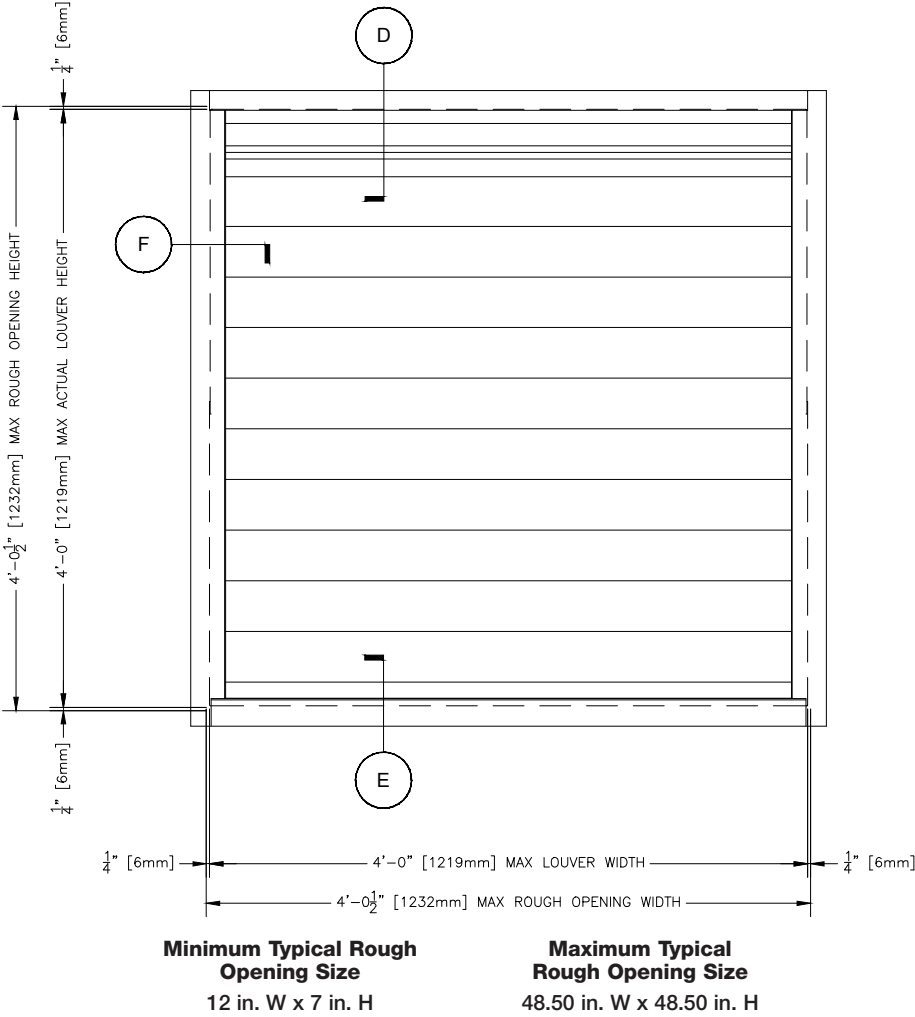

Building Condition/Substrate Limitations

Flange/Sleeve Installation

- Any substrate acceptable that is capable of withstanding imposed loads.

Flange/Sleeve Installation

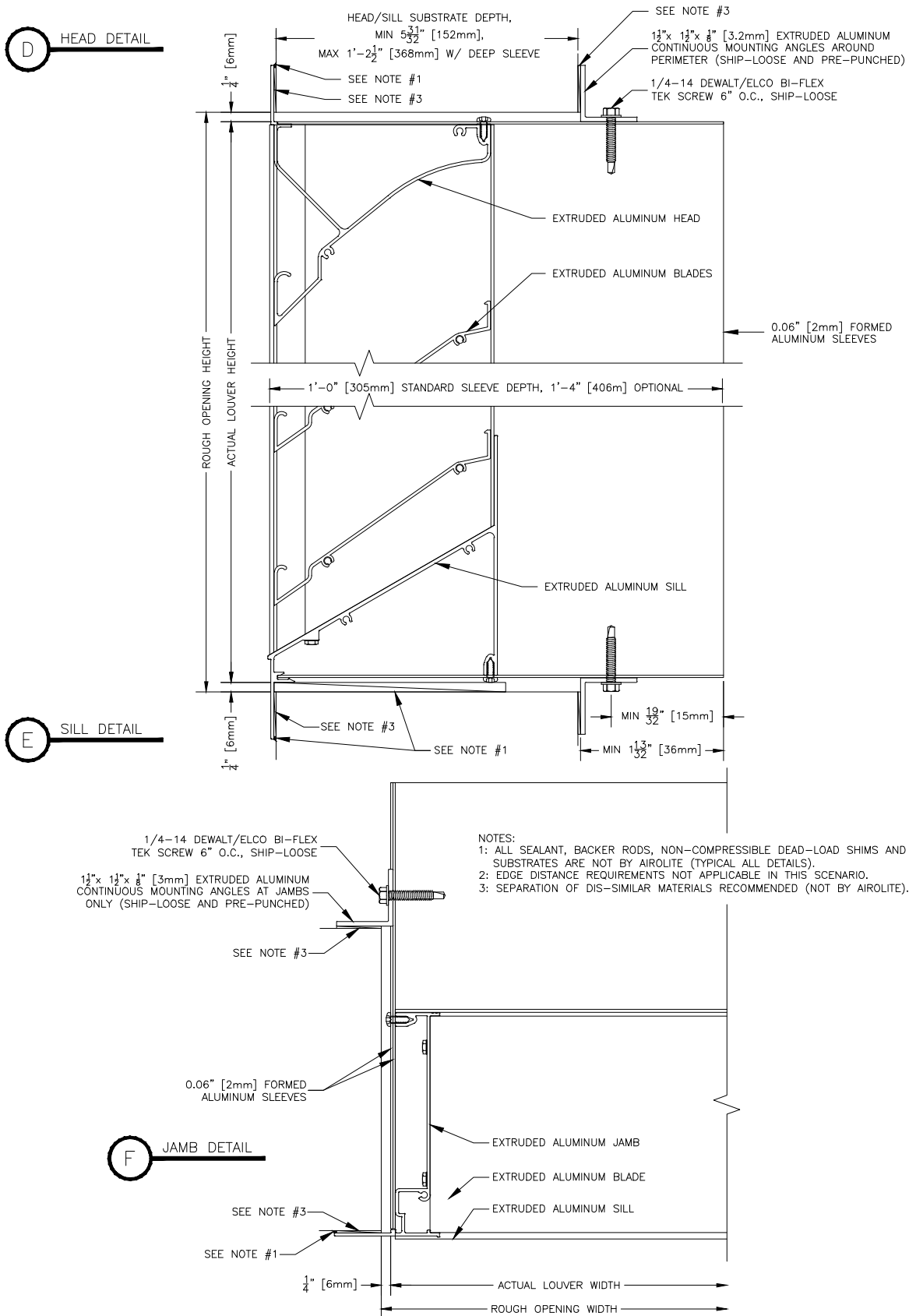

Flange/Sleeve Installation

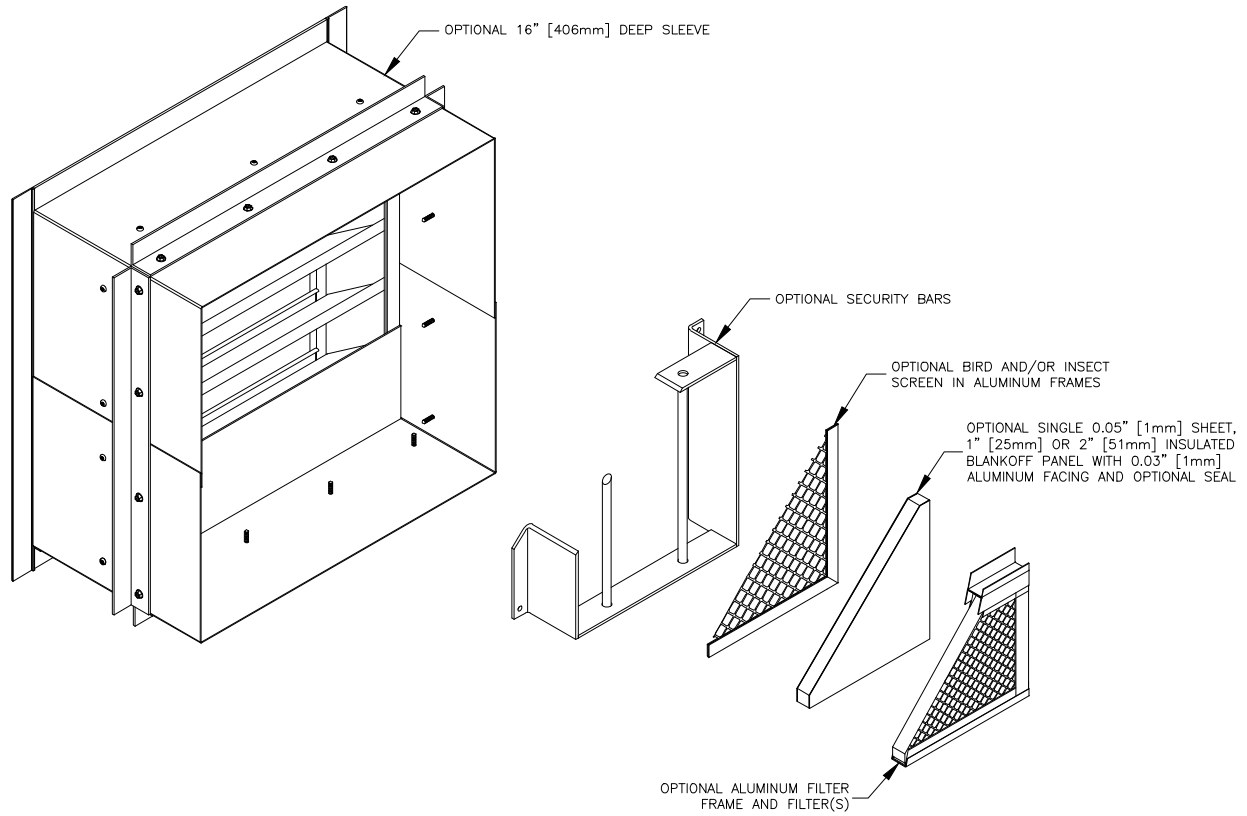

P.O. Box 410, 525 Western Road, Schofield, WI 54476-0410 USA
715.841.8757 • fax 715.841.8773 • www.airolite.com

As a result of our commitment to continuous improvement, AiroLite reserves the right to change specifications without notice.